



# HAYWARD®

## Industrial Products, Inc.

One Hayward Industrial Drive  
Clemmons, North Carolina 27012  
Phone: 336-712-9900  
FAX: 336-712-9518  
e-mail: industrial@haywardnet.com

# Installation, Operation & Service Instructions

Webster® MAG  
Corrosion Resistant Mag Pump  
SERVICE MANUAL  
1M03 to 1M14

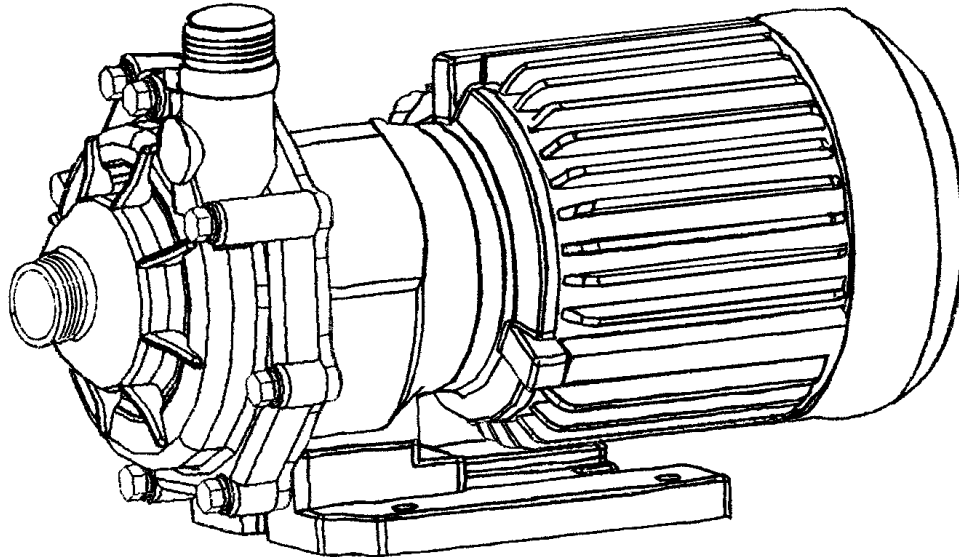

**PLEASE READ THE FOLLOWING INFORMATION  
PRIOR TO INSTALLING AND USING  
Webster® PUMPS or HAYWARD VALVES,  
STRAINERS, FILTERS, AND OTHER  
ASSOCIATED PRODUCTS. FAILURE TO  
FOLLOW THESE INSTRUCTIONS MAY RESULT  
IN SERIOUS INJURY.**

1. Webster and Hayward guarantees their products against defective material and workmanship only. Webster and Hayward assume no responsibility for damage or injuries resulting from improper installation, misapplication, or abuse of any product.
2. Webster and Hayward assume no responsibility for damage or injury resulting from chemical incompatibility between their products and the process fluids to which they are subjected. Compatibility charts provided in Webster and Hayward literature are based on ambient temperatures of 70 °F and are for reference only. Customer should always test to determine application suitability.
3. Consult Webster and Hayward literature to determine operating pressure and temperature limitations before installing any Webster and/or Hayward product. Note that the maximum recommended fluid velocity through any Webster and Hayward product is eight feet per second. Higher flow rates can result in possible damage due to the water hammer effect. Also note that maximum operating pressure is dependent upon material selection as well as operating temperature.

4. Webster and Hayward products are designed primarily for use with non-compressible liquids. They should NEVER be used or tested with compressible fluids such as compressed air or nitrogen.
5. Systems should always be depressurized and drained prior to installing or maintaining Webster and Hayward products.
6. Temperature effect on piping systems should always be considered when the systems are initially designed. Piping systems must be designed and supported to prevent excess mechanical loading on Webster and Hayward equipment due to system misalignment, weight, shock, vibration, and the effects of thermal expansion and contraction.
7. Because PPL, PVC and CPVC plastic products become brittle below 40 °F, Webster and Hayward recommends caution in their installation and use below this temperature.
8. Published operating torque requirements are based upon testing of new valves using clean water at 70 °F. Valve torque is affected by many factors including fluid chemistry, viscosity, flow rate, and temperature. These should be considered when sizing electric or pneumatic actuators.

Due to differential thermal expansion rates between metal and plastic, transmittal of pipe vibration, and pipe loading forces **DIRECT INSTALLATION OF METAL PIPE INTO PLASTIC CONNECTIONS IS NOT RECOMMENDED.** Wherever installation of plastic valves into metal piping systems is necessary, it is recommended that at least 10 pipe diameter in length of plastic pipe be installed upstream and downstream of the plastic valve to compensate for the factors mentioned above.

**CAUTION: Do not attempt to install or remove the PUMP from a pressurized pipeline.**

**Shut down the pump, isolate the pump and drain the pipeline before removing, installing or servicing the pump.**

MAGIS053  
REV A 6/2002  
ECR965S  
08EV.DOC  
Page 1 of 8

### **THREADED CONNECTION:**

Threaded end connections are manufactured to ASTM specifications D2464-88, F437-88 and ANSI B2.1. Wrap threads of pipe with Teflon tape of 3 to 3-1/2 mil thickness. The tape should be wrapped in a clockwise direction starting at the first or second full thread. Overlap each wrap by, 1/2 the width of the tape. The wrap should be applied with sufficient tension to allow the threads of a single wrapped area to show through without cutting the tape. The wrap should continue for the full effective length of the thread. Pipe sizes 2" and greater will not benefit with more than a second wrap, due to the greater thread depth. To provide a leak proof joint, the pipe should be threaded into the end connection "hand tight". Using a strap wrench only. (Never use a stillson type wrench) tighten the joint an additional 1/2 to 1-1/2 turns past hand tight. Tightening beyond this point may induce excessive stress that could cause failure.

### **FLANGED CONNECTION:**

Flange bolts should be tight enough to slightly compress the gasket and make a good seal, without distorting or putting excessive stress on the flanges. Suitable washers should be used between the bolt head and flange and the nut and flange. Bolts should be tightened in alternating sequence.

#### **RECOMMENDED FLANGE BOLT TORQUE**

FLANGE SIZE	BOLT DIA	TORQUE FT. LBS.
1-1/2	1/2	10-15

**NOTE: USE WELL LUBRICATED METAL BOLTS AND NUTS. USE SOFT RUBBER GASKETS.**



## **1. FORWARD**

Thank you for purchasing a Webster magnetic drive pump. Following the procedures and suggestions in this manual should maximize the pump's performance and assure long-term pump efficiency.



## **2. SAFETY PRECAUTIONS**

The following procedures are intended to protect you from personal injury and/or property damage.







- The following symbols classify the degree of danger and explain the damages that could occur if the warnings and cautions are ignored.

	<b>Warning:</b> Non-compliance can lead to fatal or serious injury.
	<b>Caution:</b> Non-compliance can lead to some injury and/or property damage.

- The types of rules to be observed are classified and explained under the following symbols.

	This symbol <b>cautions people to be careful.</b>
	This symbol signifies a <b>particular action is banned.</b>
	This symbol indicates that the <b>action must be taken.</b>









## **Caution**

-  (1) **Dangerous liquids, and dangerous surroundings.**  
When using the pump to move dangerous liquids or when using in surroundings (only explosive prevention specifications) liable to cause explosions, you must adhere to facility standards determined by law and always conduct daily check ups to look for and prevent leaks.
-  (2) **Do not use damaged or modified pumps.**  
Using damaged or modified pumps could be dangerous, leading to personal injuries, electric shock and breakdown of the pump. Do not use damaged or modified pumps, as they will not be covered by our company's warranty.
-  (3) **Caution when transporting or lifting the pump.**  
Using a belt sling, hoist pumps carefully. Watch the weight balance. Qualified personnel must perform this operation and the slings used should have sufficient strength.  
Do not carry pumps by hand as even the lightest pump weighs more than 20 pounds (10 kilograms).
-  (4) **Do not inspect or dismantle the pump or the motor with the power on.**  
Do not inspect or dismantle the pump or motor with the power turned on. This could lead to personal injuries caused by electric shock or injuries caused by getting caught in the rotor. This work should be performed only after verifying the multiple safety devices such as the switch for main power supply, the operations switch, and the hand switch for the pump are off.
-  (5) **Protecting the power supply cord.**  
Over-stretching, sandwiching and damaging power supply cords or motor lead wires could damage the cable and cause fire or electric shock. Always replace the cover of the terminal box and the gasket in its original position before use.
-  (6) **Attaching current leak circuit breaker.**  
Electric shock might result if the pump is used without attaching a current leak circuit breaker. Protect the pump from accidents and damages caused by current overload by always attaching circuit breakers and/or other protective devices.
-  (7) **Caution when removing pump.**  
Always close the intake and discharge pipe valves and verify there are no liquid leaks before removing the pump from piping. Always wear protective gear when performing these operations as direct contact with the fluids could cause injuries.

**CAUTION: Do not attempt to install or remove the PUMP from a pressurized pipeline.**

**Shut down the pump, isolate the pump and drain the pipeline before removing, installing or servicing the pump.**

# ⊘ Caution

-  (1) **Unspecified use.**  
Do not use the pump for purposes other than those stipulated by the specifications on the nameplate. Unspecified use could cause personal injuries or damage to the pump and peripheral equipment.
-  (2) **Restrictions on persons handling the pump**  
Transportation, installation, wiring, operation, servicing, and inspection should be performed only by an expert who has full knowledge on handling the pump.
-  (3) **Opening package.**  
Please open the package only after verifying which side of the package is the top and which side is the bottom. When opening a wooden crate, be careful so as not to injure yourself from nails and splinters when removing the product.
-  (4) **Ventilation**  
Do not place objects around the pump that might obstruct ventilation as the motor could heat up. In handling toxic or odorous liquids, have the pump situated in a well-ventilated place to prevent poisoning.
-  (5) **Repairs and returning the pump.**  
When the pump breaks down contact Webster's main office in Clemmons, NC or your nearest sales agent for repairs. If the pump is to be sent back for repairs, wash the inside and outside of the pump with clean water and package it in a vinyl bag wrapping after verifying that it is free of any chemical agents.
-  (6) **Regarding plastic (resin) parts.**  
The pump is made of resin material. Therefore, it could cause injuries if it becomes damaged through impact with other objects. Since the material is not as strong as metal, refrain from sitting on the pump. Attach piping support to avoid any pipe load burdening the pump.
-  (7) **Starting the pump**  
Verify the direction of rotation when initially starting up the pump. Verify the openings of the intake and discharge valves, and check that the pipes are arranged so that there is no liquid leakage. Turn on the switch within a second after the pipe is emptied of air and the pump is filled with liquid. Then, verify the direction of rotation. If the rotation is in reverse, switch two of the three phases in the three-phase power supply to change the direction of rotation. Always turn off the power supply and confirm that it is safe before switching the two phases.
-  (8) **Disposing of scrapped pump.**  
When disposing a scrapped pump, dispose of any chemical agents clinging to the pump and discard as industrial waste in accordance with the law.

## Inspection when unpacking the pump!

Inspect the following and contact the source where the pump was purchased, if any abnormality is found.

- (1) Check to see if the type, total lift, discharge volume, motor specification and voltage specification on the pump and motor nameplates comply with the ordered specifications.
- (2) Check all auxiliary parts.
- (3) Check for loose bolts or damages caused by mishandling during transportation.

### Part Number Matrix

DIGIT 1	DIGIT2	FLOW (aa)	WET MATL (b)	BEARING ⊙	O-RING	CONNECT	MOTOR	HP/CONST R	SPECIAL
1	M	gpm/10	3=gfppl	C=carbon	E=EPDM	F=flange	X=none	1=1/3 TEFC	
			5=etfe	T=teflon	V=VITON (FPM)	T=thread	1=115VAC- 50/60	2=1/2TEFC	
				Z=ceramic			2=230VAC- 50/60	3=3/4TEFC	
							3=240VAC- 50/60 3PH	4=1TEFC	
								5=1.5 TEFC	
								6=2 TEFC	
								7=3 TEFC	
								8 = 5 TEFC	
								A=1/3 EXP PR	

EXAMPLE:

1M053ZT13 is a 50 gpm GFPPL pump including ceramic bearings, Viton (FPM) seals, threaded connections and a ¾ HP 110 VAC motor.

**CAUTION: Do not attempt to install or remove the PUMP from a pressurized pipeline.**

**Shut down the pump, isolate the pump and drain the pipeline before removing, installing or servicing the pump.**

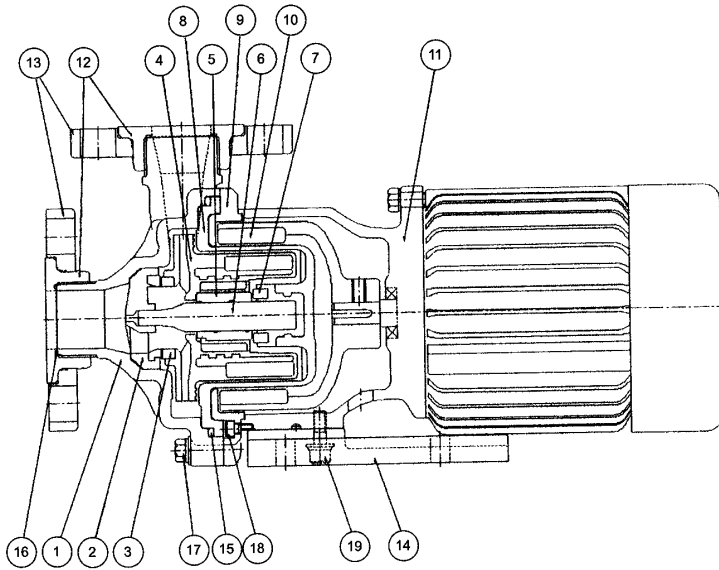

NO.	Part Name	Qty	Material		Other
1	Front Casing	1	GFR PP	CFR ETFE	
2	Liner Ring	1	alumina ceramic +GFR PPS	alumina ceramic +CFR ETFE	one unit
3	Mouse Ring	1	CFR PTFE		
4	Impeller	1	GFR PP+Magnet	CFR ETFE+Magnet	one unit
5	Shaft Bearing	1	CFR PTFE/ carbon/alumina ceramic	CFR PTFE/ *carbon/alumina ceramic	*is high density carbon
6	Shaft	1	alumina ceramic		
7	Rear Thrust Ring	1	CFR PTFE		
8	Rear Casing	1	*GFR PP+GFR PPS	CFR ETFE	*is one unit
9	Rear Casing Support	1	FC 200		
10	Outer Shaft Magnet	1	FCD 450-10+Magnet		
11	Motor Bracket	1	FC 200 (Housing Type)		
12	Lap Joint	2	GFR PP	CFR ETFE	
13	Flange	2	GFR PP	CFR ETFE	
14	Base	1	GFR PP		
15	O-ring	1	FPM	FPM	FPM: Dial
16	O-ring	2	FPM	FPM	FPM: Dial
17	Hexagonal Bolts	6/8	SUS 304	M8x60(2)+M8x35(4/6), PW, with SW	
18	Hexagonal Bolts with Holes	6	SUS 304	M6x12	
19	Hexagonal Bolts with Holes	4	SUS 304	M8x25, PW, with SW	

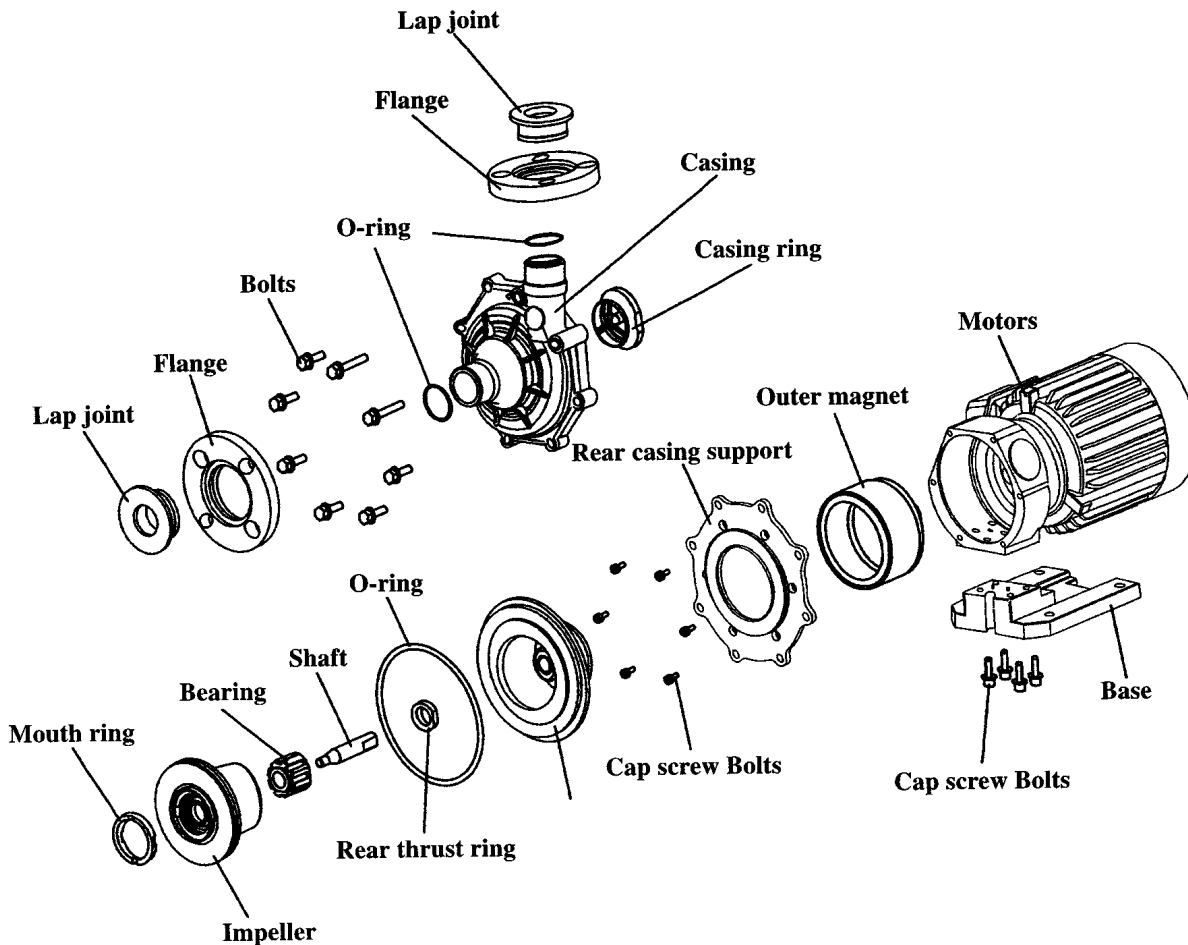

**CAUTION:** Do not attempt to install or remove the PUMP from a pressurized pipeline. Shut down the pump, isolate the pump and drain the pipeline before removing, installing or servicing the pump.

## ⊗ Caution When Handling

Because of the powerful magnetic force of this pump, extra precaution is necessary in addition to the normal precautions taken for conventional pumps. Normal precautions include, no dry running and no operating the pump in reverse rotation.

- (1) People with pacemakers and other electronic devices for maintaining bodily functions must not use this magnet pump. The magnet used in the interior is several times more powerful than ordinary magnets used every day.
- (2) Do not place your hand between the magnets. If there are articles made of iron such as knives, scissors or heavy iron masses nearby, the magnets could attract to them in an instant, causing injury to the handholding the article or causing the plastic surrounding the magnets to crack.
- (3) Do not place products that could be easily de-magnetized such as floppy disks, computer memory and magnetic tapes close to the pump.

### Prohibited on conventional magnet pumps

1. **No Dry-Running:** If the motor is run dry, the heat from the friction between the shaft and impeller bearing could cause the resin materials around the shaft and bearing to become soft. This could cause the resin material to come in contact with other parts, damaging the pump. If the pump is operated without using priming water and with the intake valve closed, dry running will occur.
2. **Slurry Liquid:** When the pump is used for liquids containing fine particles, it will increase wear and tear of the pump, thus shortening the replacement period of pump and parts to an extreme degree.
  - This occurs when the intake pipe is attached to the bottom of the liquid tank.  
(Please consult with us first when using liquid containing slurry.)
3. **Cavitation:** If the pump is used in a state where "cavitation" has occurred, it could cause the pump to vibrate or its basic performance to deteriorate, causing damage to the interior of the casing.
  - Some of the conceivable causes include: the intake pipe is too long, there are many bent sections, the liquid temperature is too high or the strainer is clogged.
4. **Erosion:** This product uses GFR-PP or CFR-ETFE resin in the main parts. When making your purchase, select after fully researching the corrosive quality of the liquid. As the life of the pump can be shortened by the type of liquid used or the temperature of the liquid, be sure to check the chemical compatibility when changing the liquid used or when the condition for use is changed.

**GFR-PP** Tolerable temperature: 32°- 176°F (0°- 80° C)  
Incompatible liquids: Nitric acid, concentrated sulfuric acid, chromium acid, hypochlorous soda, caustic soda, benzene, turpin oil, etc..

**CFR-ETFE** Tolerable temperature: 32°- 194°F (0°- 90° C)  
Incompatible liquids: none in particular

**CAUTION: Do not attempt to install or remove the PUMP from a pressurized pipeline.**

**Shut down the pump, isolate the pump and drain the pipeline before removing, installing or servicing the pump.**

## ⊗ Caution when Installing, Laying Pipes

1. Caution when installing
  - (1) If a large amount of air mixes during operation, the pump will not be able to pump the liquid, causing a breakdown.

Set the height from the pump intake mouth to the liquid surface in the tank at more than 12 inches (30 cm).  
Do not place objects that may block the passage of air in the intake pipe, nor lay the intake pipe over extremely large objects, etc.  
Arrange the intake pipe to have a gradient of more than 1/100 facing the pump.  
Use an intake pipe with a diameter larger than that of the pump.  
When the diameters are not the same, use an appropriate size pipe that will secure the pump and will remain level.
  - (2) Place a strainer at the intake mouth of the piping to prevent foreign objects from entering the pipe. However, you must periodically clean the strainer to prevent clogging so as to minimize resistance.
  - (3) It is recommended that a check valve be attached to the start up pipe on the discharge side to prevent "water hammer". Place a bypass for air exhaust on the lower section of the check valve when:
    - The discharge pipe is to be long or when the discharge lift is more than 30 ft. (10m).
    - The tip of the discharge pipe is more than 27 ft. (9m) in height over the water surface of the intake tank.
    - The pipe conditions call for using more than two pumps that are parallel to one another.
  - (4) Create bending sections or contractible joints on the piping to prevent pump deformation and thermal expansion leakage caused by increased liquid temperature.
  - (5) Handle the pump with care so as not to create any impact, as the main parts within the pump are made of resin.
2. Do not tighten the pump flange excessively.
  - (1) Arrange the pipe flange surface and the pump flange surface parallel to one another and do not tighten the bolts excessively.
  - (2) Excessively tightening the bolts can deform the pump flange when using a flexible joint, a SUS loose flange, or packing on the piping side.
3. Do not apply weight on the pipes
  - (1) The weight of the pipes should be completely supported by pipe support apparatuses.
  - (2) Create bending sections and use contractible joints on the pipes so that the pump will not be burdened with load from the thermal expansion of the pipe when the temperature is high (more than 104°F, 40°C).
  - (3) Avoid using metal pipes. Use resin pipes only.
    - Please be careful with 2 and 3 as metal pipes are frequently used for concentrated sulfuric acid and caustic acid.

## ⊗ Caution When Operating

### • Before Starting Operation

Clean the inside of the pipes and tanks.

The performance of the pump deteriorates if foreign objects enter the pump, they can cause a breakdown.

Verify that the flange connector bolts are securely fastened.

A loose bolt could cause leakage, which can cause injury to people and damage to other facilities.

Verify again there is no leakage by pouring priming water into the pump and opening the intake and discharge valves after venting the air. Verify the rotating direction of the motor.

If the motor is turning in reverse, rewire two phases of the three-phase power supply.

### • Do not run dry.

As the parts in friction are designed to be cooled, by pumped liquid through self-circulation, dry running the pump could damage the bearings. Therefore, do not run the pump dry. In the event the motor is idled do not suddenly pour in liquid. Rather, run the pump after allowing it to stand for more than one hour. A sudden flow of liquid could severely damage the frictional parts of the pump beyond repair.

- In the event liquid is trapped in the pump (intake, discharge valve both closed), the temperature and pressure within the pump will increase to high levels. If the pump is dismantled and inspected in this state, steam and hot water could spew out. Because of the danger involved, perform these operations only after the temperature fully declines. Be careful not to operate the pump with trapped liquid, as this could damage the pump.
- Keep in mind that there will be differences in vapor pressure, viscosity, and corrosiveness depending on the temperature of the liquids handled when using the pump. Allow a certain margin of temperature when using the pump.

Scope of liquid temperature for using the pump:

32-176°F (0- 80 °C) GFPPL

32-194°F (0- 90°C) ETFE

- (1) In the event the specific gravity and viscosity increases, the pump's performance capacity, efficiency, and axial movement power will change. Please take this into consideration and use within an appropriate range.
- (2) The pump has been made under specifications decided at the time of purchase. In the event you decide to change the specification conditions, please verify the new operational point before continuing.

**CAUTION: Do not attempt to install or remove the PUMP from a pressurized pipeline.**

**Shut down the pump, isolate the pump and drain the pipeline before removing, installing or servicing the pump.**

## Maintenance Inspection, Spare Parts

1. Routine Inspection
  - (1) Verify that there are no vibrations or any abnormal noises from the pump and that it operates smoothly.
  - (2) Compare current value during operation with the rated current value and verify that the operating load of the motor is normal. Also, verify whether the discharge pressure, discharge volume and current value during operation are within the values of previous operations.
  - (3) Inspect the surface level of the intake tank.
2. Periodic Inspection
  - (1) Periodically overhaul the motor to ensure smooth operation of the PUMP.
  - (2) Completely drain the pump wash with water for safety purposes when moving the pump to change installation sites or for repairs.
3. Inspecting Spare Parts: **Periodically inspect the following spare parts.**
  - (1) Mouth Ring  
Check the wear and tear of the mouth ring by viewing the ring from the front of the impeller. Use the grooves (two) on the mouth ring as the criteria for replacement.  
If the grooves are worn out to the degree of being indistinguishable, replace the ring.
  - (2) Bearing  
Check for cracks or chips on the carbon or on the alumina ceramics.  
Verify that there is not too much play between the shaft and the bearing.
  - (3) Rear Thrust Ring  
If the impeller has worn down to the point that it touches the rear casing, replace the ring.
  - (4) Shaft  
Check the shaft for cracks and chips.
  - (5) Liner Ring  
Check the alumina ceramics for cracks and chips.
  - (6) Impeller  
Replace the impeller if there are signs of wear, tear and corrosion on the surface surrounding it.
  - (7) Rear Casing  
Examine the interior of the rear casing for signs of wear and tear and deterioration caused by corrosion, and look for wear and tear and cracks on the rear side of the casing.
  - (8) Front Casing  
Replace the casing if you see signs of wear and tear and deterioration from corrosion in the front casing.

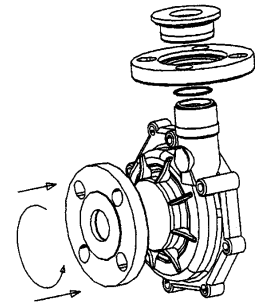
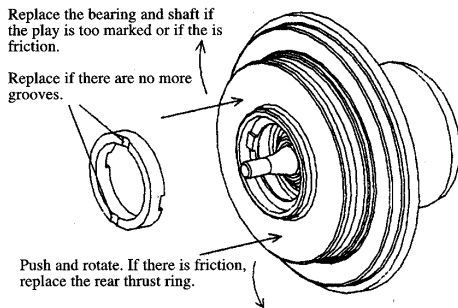

## Dismantling and Assembling

Please be careful when handling the magnet used in the pump during dismantling or assembling as its magnetic force is powerful.

1. Dismantling
  - (1) Drain the pump of liquids. At this time thoroughly wash the interior of the pump.
  - (2) Remove the hexagonal bolt(s) on the front casing and remove from the front casing bracket.
  - (3) Remove the impeller by pulling forward. Be very careful when handling, so as not to damage the sections.
  - (4) Inserting a screwdriver between the circumference section of the casing and the casing support then lightly lifting it up, and removing it forward can easily remove the rear casing.
  - (5) When removing the bearing from the impeller, insert a cylindrical object into the hole in the front of the impeller.

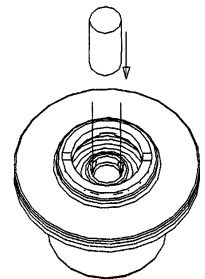

### 2. Assembling

Assemble the pump in the reverse order of dismantling. Clean the friction parts and O-ring thoroughly so that the surface is not damaged or filthy. Tighten the bolts for each section uniformly.

#### Caution:

- (1) Use plastic or wooden spacers to protect your fingers from injury as the magnetic force of the magnet is very powerful.
- (2) When re-assembling the pump after it has been dismantled, it is recommended that the O-ring be replaced. If the O-ring is reused it could cause liquid leakage.
- (3) After assembling the pump, ensure that the impeller rotates smoothly before reinstallation.

**CAUTION: Do not attempt to install or remove the PUMP from a pressurized pipeline.**

**Shut down the pump, isolate the pump and drain the pipeline before removing, installing or servicing the pump.**

## Troubleshooting

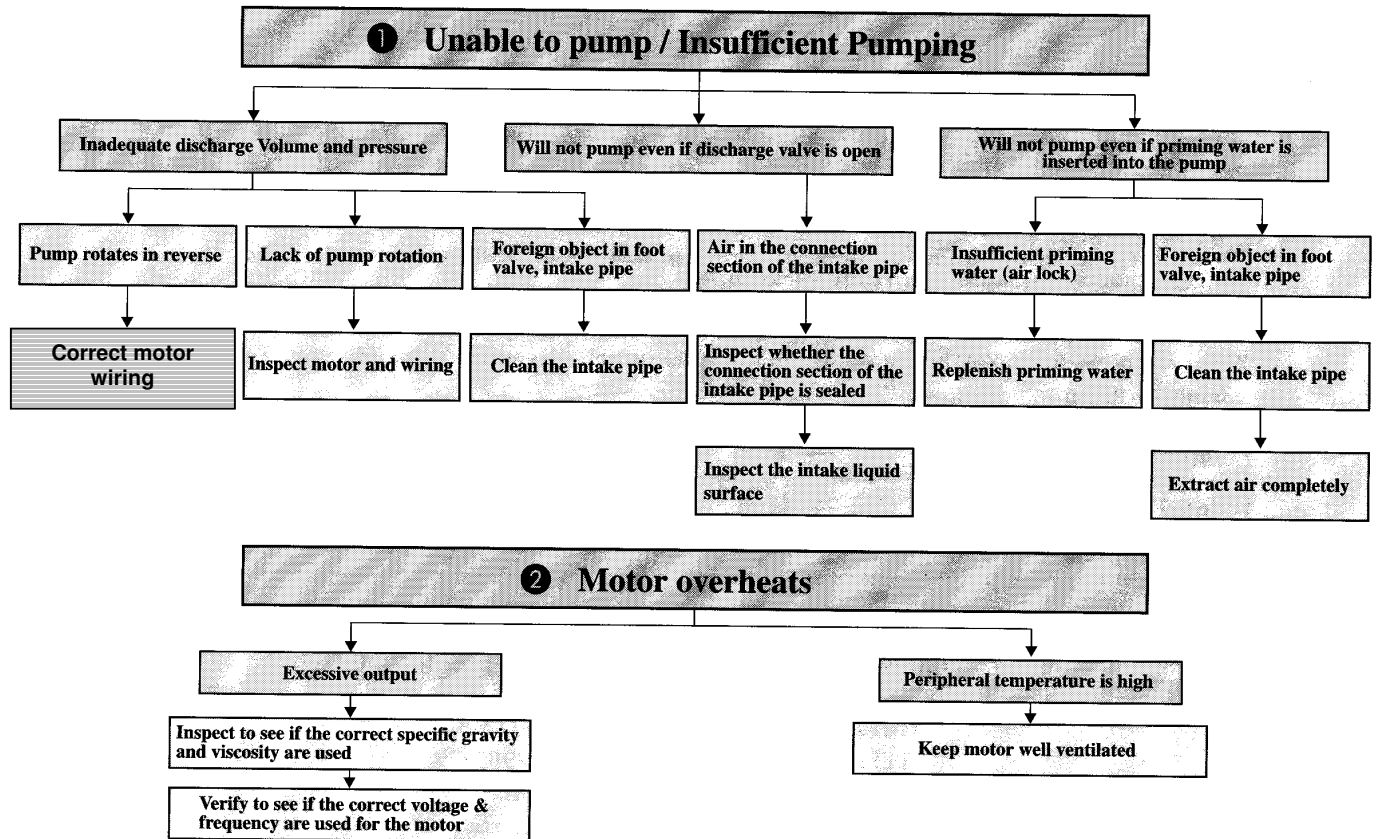

## Specifications:

Model	50 Hz Max Head m	50 Hz Max Flow lpm	60 Hz Max Head ft (m)	60 Hz Max Flow gpm (lpm)	Connection Inlet x Outlet NPTM	Motor output HP (kW)
1M03	8.8	120	41 (12.4)	36 (135)	1" x 1"	1/3 (.26)
1M05	14.3	220	50 (15.2)	53 (200)	1 1/2" x 1 1/2"	3/4 (.55)
1M08	19.5	320	70 (21.0)	82 (300)	1 1/2" x 1 1/2"	1 (.75)
1M10	26	415	89 (27.6)	106 (360)	2" x 1 1/2"	2 (1.5)
1M12	30	445	108 (33.0)	119 (445)	2" x 1 1/2"	3 (2.2)
1M14			131 (43.0)	140 (530)	2" x 1 1/2"	5 (3.7)

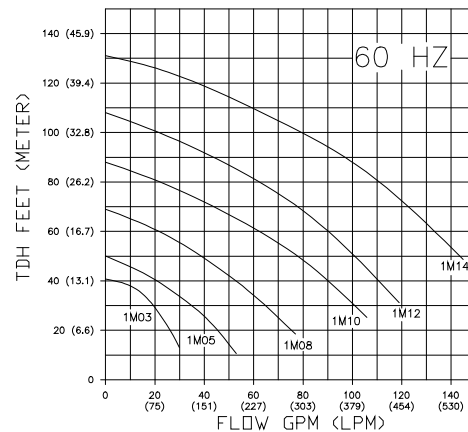
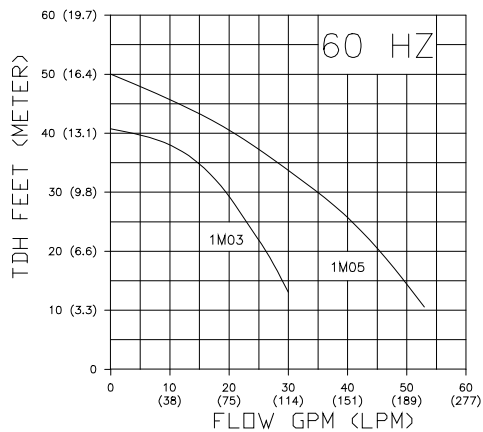

**CAUTION: Do not attempt to install or remove the PUMP from a pressurized pipeline.**

**Shut down the pump, isolate the pump and drain the pipeline before removing, installing or servicing the pump.**